

TECHNICAL SPECIFICATION

Shanty

DOSHI LEVIEN
2014



COMPONENTS and MATERIALS:

CONTAINERS are manufactured of MDF fiberboards in a matte lacquered finish. The containers are attached together using a mechanical fixing system.

DOORS are made of MDF fiberboard with mechanised wave-form fronts, and matte lacquered finish.

The **GLASS TOP** is 8mm thick and transparent. The colour will always remain on the bottom side of the glass to avoid any damage. Octagonal **LEGS** made of extruded anodised aluminum or painted in different colours. At the bottom of each leg there is a plastic screw system which works as a regulator.

The **STRUCTURE** is made of tubular iron with welded strips to assemble the legs.

OPENING SYSTEMS: a combination of hinges, folding door system and drawers.

DRAWERS: installed guides with full extraction braking system. The maximum load (weight) is 35 kg.

FINISHES:

CONTAINERS are available in two colours in a matte finish: white or black.

DOORS come in patchwork finishes - Summer and or Winter.

GLASS is painted according to the colours of containers: white or black.

LEGS are anodised in matte gold or gloss lacquered in white or black. The **STRUCTURE** is lacquered in a matte finish in a colour that matches the container: white or black.

DIMENSIONS and WEIGHTS:

Model A 2060x979x526mm – 138Kg

Model B 2083x979x526mm – 154Kg

Model C 1298x979x526mm – 78Kg

PACKAGING:

All models are dismantled for shipment. Modules come in separate boxes. The glass is provided in a reinforced wooden box.

CLEANING and MAINTENANCE:

The furniture should be cleaned with a damp cloth and neutral soap. Use of organic wipes is recommended. Do not clean with any alcohol or solvents, or apply any other cleaning product containing these derivatives.

Model A

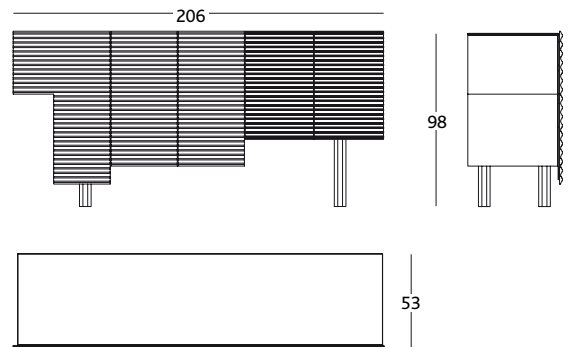

Model B

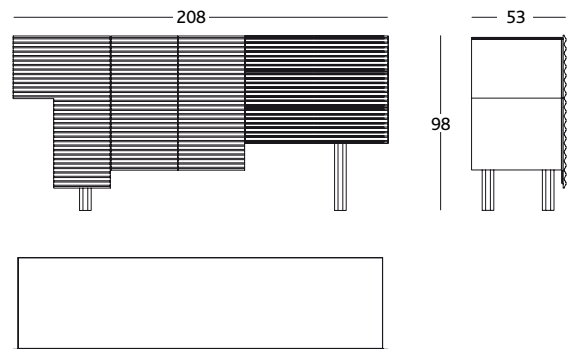

Shanty Small

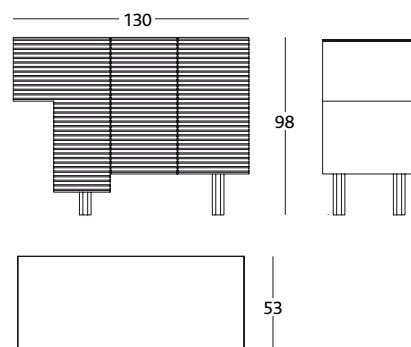

MEASUREMENTS IN MM



BD Barcelona Design
Ramon Turró, 126 / 08005 Barcelona
Tel +34 93 458 69 09 / Fax +34 93 207 36 97
bd@bdbarcelona.com / www.bdbarcelona.com

Technical Department
Carretera Capellades / km 22,750
Narcís Monturiol, 7 / Pol. Ind Sesrovires
Sant Esteve de Sesrovires / 08635 Barcelona
Tel +34 93 771 30 51 / Fax +34 93 771 32 32