

TREKU



Aura Collection

PRODUCT DATA SHEET

1901

1/3

Model: Aura
Manufactured in: Spain-Europe (EU)
Designers: Angel Marti/Enrique del Amo

The Aura collection has been conceived mainly for sideboards and furniture for living rooms and dining rooms. Its design is inspired by the past and under the influence of the design culture of the Nordic countries, which know how to combine tradition and naturalness with large doses of modernity. The result: a collection full of memories that gives off a very modern aura. The metal and wood legs designed especially for the collection reinforce that retro and timeless look. The finish is very important: walnut and oak wood with a hyper-natural finish and a lacquered look which combine perfectly well with the wood.

1. Composition

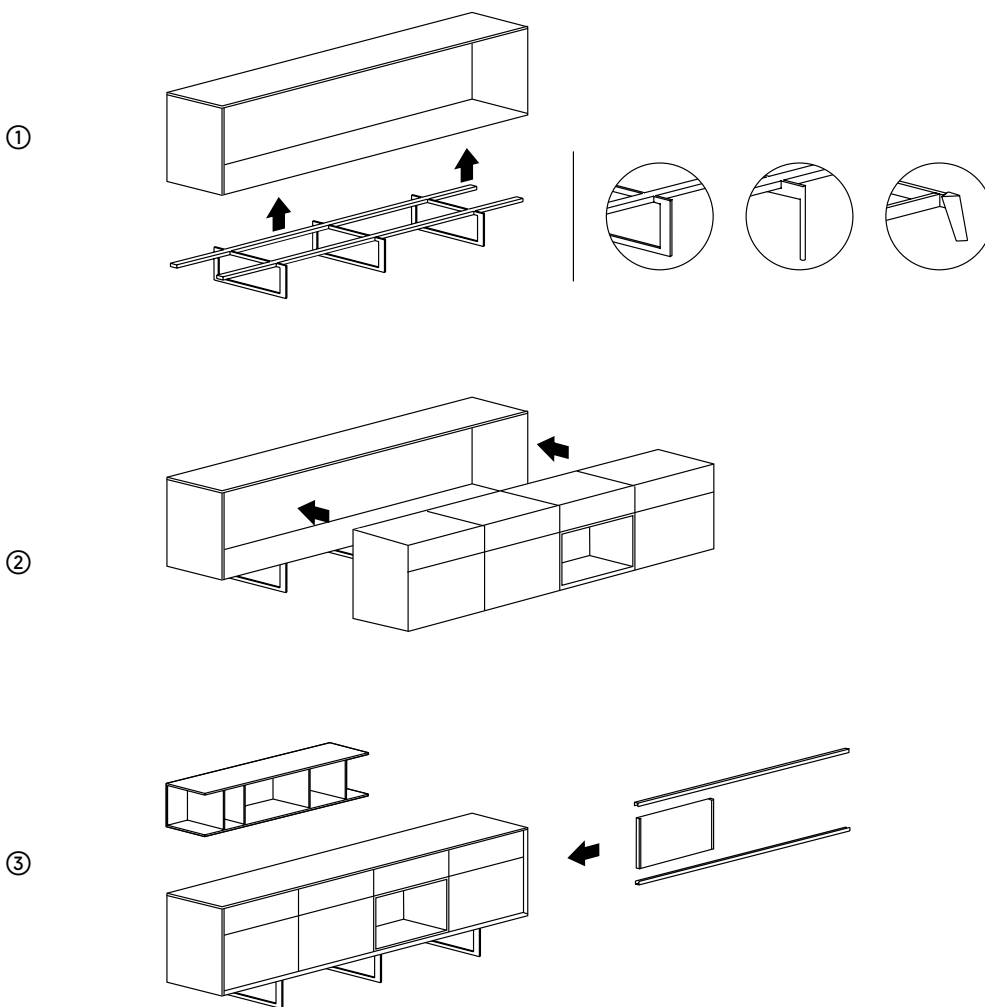

1

Choose dimensions of frame and add plastic, wooden or metal legs.

2

Place units in frame.

3

Optional: add sliding doors or wall-mounted units.

2. Materials

Legs

Metal: Steel coated with epoxy paint. Provided with height adjusters.

Wood: Beech solid wood covered with wood veneer. Coated with polyurethane varnish.

Frame

Wood: Particleboard covered with natural wood veneer. Edges in wood veneer. Faces coated with UV cured acrylic and edges varnished with polyurethane.

Lacquer: Particleboard covered with DM. Base coat UV varnished and finished with acrylic.

Units

A) Open units:

Wood: Particleboard covered with natural wood veneer. Edges in wood veneer. Faces coated with UV cured acrylic and edges varnished with polyurethane.

Lacquer: Particleboard covered with DM. Base coat UV varnished and finished with acrylic.

B) With doors and drawers:

Exterior: Wood: Particleboard covered with natural wood veneer. Edges in wood veneer. Faces coated with UV cured acrylic and edges varnished with polyurethane.
Lacquer: Particleboard covered with DM. Base coat UV varnished and finished with acrylic

Interior: Melamine board with open pore finishing.
Glass sliding doors: 4mm tempered glass.
Hardware: Hettich tracks and Blum hinges.

C) Glass sliding doors: 4mm tempered glass

D) Hardware: Hettich tracks and Blum hinges

3. Finishes

Exterior:

Treku Woods
Treku Lacquers
Fumé glass
Dark grey glass

Interior:

Graphite laminate

4. Product maintenance

For cleaning use a cloth moistened with water. Do not use solvents or cleaning products. Avoid placing penetrating liquids, essential oils, perfumes, on top of the furniture.

5. Packaging and transportation

All our products are duly packaged (cardboard, foams and styrofoam). Our carriers are the most demanding for the characteristics of our products.

6. Assembly instructions

All our products include assembly instructions for their correct installation.

See attached document.

Units and chest of drawers are assembled at the factory. For any technical question, do not hesitate to contact our technical department.

7. Warranty

The products have 2 years guarantee as long as its installation is carried out by professionals of the sector and the use of the material is adequate. Treku accepts no liability for any incident arising from the mishandling of the materials supplied.

Wood, being a natural product, may have small differences in texture, color and pattern. Treku is not responsible for any minor differences that may arise.

Because of its natural origin, the wood with time may suffer differences in color and texture, so we cannot ensure homogeneity of color in additional orders.

Frames (Depth 47)

Total Height 36 Internal height 32

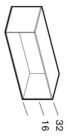

Total frame width Add 4cms to the internal width
 Internal width (cm) 64 80 96 128 144 160 176 192 208 224 240 256 272 288 304 320

Total Height 52 Internal height 48

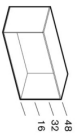

Total frame width Add 4cms to the internal width
 Internal width (cm) 64 96 128 144 160 176 192 208 224 240 256 288 304 320

Total Height 68 Internal height 64

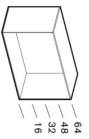

Total frame width Add 4cms to the internal width
 Internal width (cm) 64 96 128 144 160 176 192 208 224 240 256 288
 Add 4cms to the internal width
 128 144 160 176 192 208 224 240 256

Total Height 100 Internal height 96

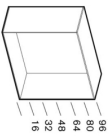

Total frame width Add 4cms to the internal width
 Internal width (cm) 64 96 128 144 160 176 192

Total Height 116 Internal height 112

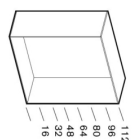

Total frame width Add 4cms to the internal width
 Internal width (cm) 64 96 128 144 160 176 192

Total Height 132 Internal height 128

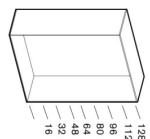

Total frame width Add 4cms to the internal width
 Internal width (cm) 64 96 128 144 160 176 192

Legs, metallic and wooden feet (required)

Adjustable plastic Legs Height 1,7

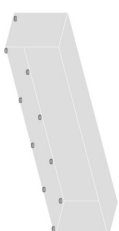

Width (cm) 64 80 96 128 144 160 176 192 208 224 240 256 272 288 304 320

Frame with metallic feet Depth 47

Finish: Graphite.
 Note: At 208 a center leg is added.



SKATE LEG



CYLINDRICAL LEG

Width (cm) 64 80 96 128 144 160 176 192 208 224 240 256 272 288 304 320

Frame with wooden legs Depth 47

Note: From 192 a center leg is added.



Width (cm) 64 80 96 128 144 160 176 192 208 224 240 256 272 288 304 320

AURA HIGH SIDEBARDS

Frame (depth 35 and 47) + metallic feet

Finish: Graphite.

Note: Depth 35 cms and Depth 47 cms same price.

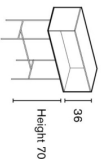

Width 100

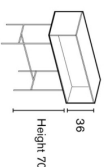

Width 132

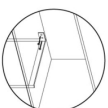

Note: The legs of the sideboard must be fixed to the wall. See detail. Distance between wall and leg: 28cm.

Units for frames (Depth 47)

Note: Weight: Don't put TV or heavy things on open units without dividers.

Note: Modules measuring 32 in height can be made with a depth of 35 for the same price as a depth of 47.

Height	Width 48	Width 64	Width 80	Width 96	Width 128
16					

Height	Width 32	Width 48	Width 64
32			

Width 64	Width 80	Width 96	Width 128

Height	Width 32	Width 48	Width 64	Width 96	Width 128
48					

Height	Width 32	Width 48	Width 64	Width 96	Width 128
64					

Wall units



Note: The divider can be the same color or a different color from the rest of the shelving.

Width 80

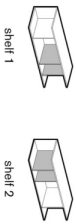

Width 96



Width 128



Height 22
Depth 25

Width 32



Width 32



Width 80



Height 32
Depth 32

Width 96

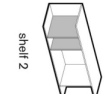
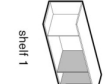
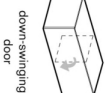
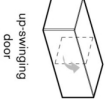

Accessories

Pull

3cm



Cable holder

6cm



Fabric lined tray

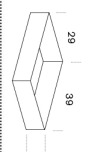

Finish: Graphite

Note: The pulls are decorative, as the doors and drawers are fitted with a push-to-open system.

A 16-cm drawer front can be split into two 8-cm fronts



Close-up of open drawer

Fully removable runners



Inner laminated shelf



Shelf for open unit



AJAR

120 Johnston Street, Collingwood 3066 VIC
T +61 3 9417 0015
ajar.com.au

Sliding doors

Pair of tracks for sliding doors

Note: Necessary for sliding doors



Width (cm)

64 80 96 128 144 160 176 192 208 224 256 272 288 304 320

Sliding doors (for frames)

Height 32

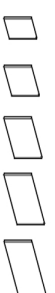

Height 48



Width (cm)

32 48 64 80 96 32 48 64



Close-up of the door. The finish of the door handle must be specified, if not it will be the same finish as the door.