



Castle S 60

By
Stone Designs

Decorative
Lighting

Suspension
lamps

Descripción

Luminaria LED de suspensión fabricada en aluminio, con cuerpo circular y difusor de PMMA blanco opal de alta uniformidad. Permite múltiples composiciones con una única acometida. Acabados: blanco mate texturado, negro mate texturado, y roble natural. Disponible en tres tamaños. Dimmer.

Descripción técnica			Packaging		
Grado de Estanqueidad	IP20	Regulación	PUSH/DALI	Peso Neto Unidad	2,00 Kg
Clase	II	Tipo de luz	LED	Medidas Caja	72,5 x 72 x 22 cm - 12 m3
Regulable	DIM	Fuente de luz incluida	Si	Peso Bruto	--
Casambi	Bluetooth	Clasificación energética	C		
Certificaciones					

Acabados

SHADE



Black

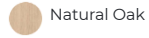

Natural Oak



White

Colección



Castle C



Castle S

Codes

Luminaria

Fuente de Luz

737311	CASTLE S60 WHITE	LED 17,4W 3416lm 150mA 3000K CRI>=90 230V DIM PUSH/DALI
73731	CASTLE S60 BLACK	LED 17,4W 3416lm 150mA 3000K CRI>=90 230V DIM PUSH/DALI
2	CASTLE S60 OAK	LED 17,4W 3416lm 150mA 3000K CRI>=90 230V DIM PUSH/DALI
73731		
3		

DESCARGAS

↓ Castle_S_Assembly.pdf

↓ Castle_S_3D.zip

↓ Castle_S_Photometry.zip

↓ Castle_S_2D.pdf

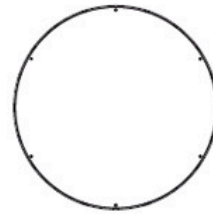
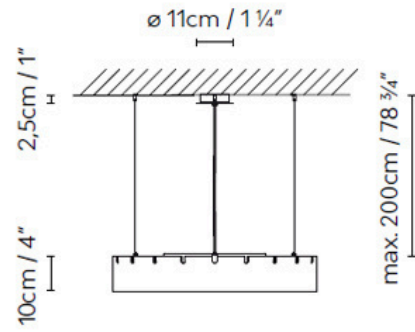



Castle S 90

By
Stone Designs

Decorative
Lighting

Suspension
lamps

Descripción

Luminaria LED de suspensión fabricada en aluminio, con cuerpo circular y difusor de PMMA blanco opal de alta uniformidad. Permite múltiples composiciones con una única acometida. Acabados: blanco mate texturado, negro mate texturado, y roble natural. Disponible en tres tamaños. Dimmer.

Descripción técnica			Packaging		
Grado de Estanqueidad	IP20	Regulación	PUSH/DALI	Peso Neto Unidad	2,00 Kg
Clase	II	Tipo de luz	LED	Medidas Caja	97 x 97 x 19 cm - 179 m3
Regulable	DIM	Fuente de luz incluida	Si	Peso Bruto	--
Casambi	Bluetooth	Clasificación energética	C		
Certificaciones					

Acabados

SHADE



Black



Natural Oak



White

Colección



Castle C



Castle S

Codes

Luminaria

Fuente de Luz

737331	CASTLE S90 WHITE	LED 41W 7960lm 350mA 3000K CRI>=90 230V DIM PUSH/DALI
73733	CASTLE S90 BLACK	LED 41W 7960lm 350mA 3000K CRI>=90 230V DIM PUSH/DALI
2	CASTLE S90 OAK	LED 41W 7960lm 350mA 3000K CRI>=90 230V DIM PUSH/DALI
73733		
3		

DESCARGAS

↓ Castle_S_Assembly.pdf

↓ Castle_S_3D.zip

↓ Castle_S_Photometry.zip

↓ Castle_S_2D.pdf

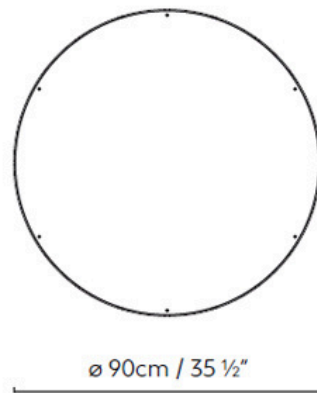
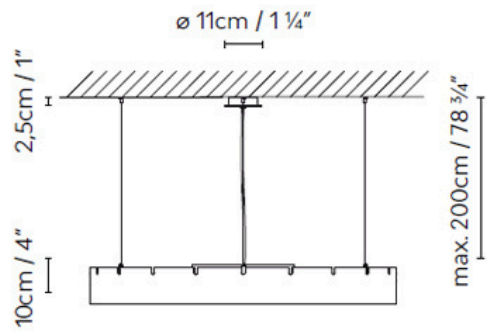



Castle S 120





By
Stone Designs

Decorative
Lighting

Suspension
lamps

Description

Round aluminum LED suspension lamp with a highly uniform opal white PMMA diffuser. It allows multiple configurations with a single connection. Finishes: textured matte white, textured matte black and natural oak. Available in three sizes. Dimmer.

Technical Description			Packaging		
Degree of Protection		Regulation	PUSH/DALI	Net Weight per Item	2.00 Kg
Class		Light type	LED	Box Sizes	130 x 130 x 21 cm - 35 m ³
Adjustable		Light source included	Yes	Gross Weight	--
Casambi		Energy classification	C		
Certifications					

Finishes

SHADE

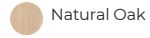

Collection



Castle C



Castle S

Codes

Luminaire

Light Source

737351

CASTLE S120 WHITE

LED 19,5W 3664lm 225mA + LED 41W 7960lm 350mA 3000K
CRI>=90 230V DIM PUSH/DALI

73735

CASTLE S120 BLACK

LED 19,5W 3664lm 225mA + LED 41W 7960lm 350mA 3000K
CRI>=90 230V DIM PUSH/DALI

2

CASTLE S120 OAK

LED 19,5W 3664lm 225mA + LED 41W 7960lm 350mA 3000K
CRI>=90 230V DIM PUSH/DALI

73735

3

Finishes

SHADE



Black



Natural Oak



White

Collection



Castle C



Castle S

Codes

Luminaire

Light Source

737351

CASTLE S120 WHITE

LED 19,5W 3664lm 225mA + LED 41W 7960lm 350mA 3000K
CRI>=90 230V DIM PUSH/DALI

73735

CASTLE S120 BLACK

LED 19,5W 3664lm 225mA + LED 41W 7960lm 350mA 3000K
CRI>=90 230V DIM PUSH/DALI

2

CASTLE S120 OAK

LED 19,5W 3664lm 225mA + LED 41W 7960lm 350mA 3000K
CRI>=90 230V DIM PUSH/DALI

73735

3

DOWNLOADS

↓ [Castle_S_Assembly.pdf](#)

↓ [Castle_S_3D.zip](#)

↓ [Castle_S_Photometry.zip](#)

↓ [Castle_S_2D.pdf](#)

